

**INSTRUCTIONS:**

1. Insert the bare terminal end of the 510096 into the mating accessory connector as shown below, then plug that connector back into the dash harness accessory connection.
2. Plug the power top harness, CA71716, into the motor connection and onto the power top switch.
3. Plug the remaining red wire on the CA71716 into the mating connector on the red power jumper harness.
4. Remove the 30A fuse from the "BAT 2" location in the fuse panel and replace it with the provided 30 A circuit breaker. This breaker will need to be trimmed as show below, before inserting.



www.americanautowire.com 856-933-0801

This mating connector has been pre-plugged into the dash harness from the factory.

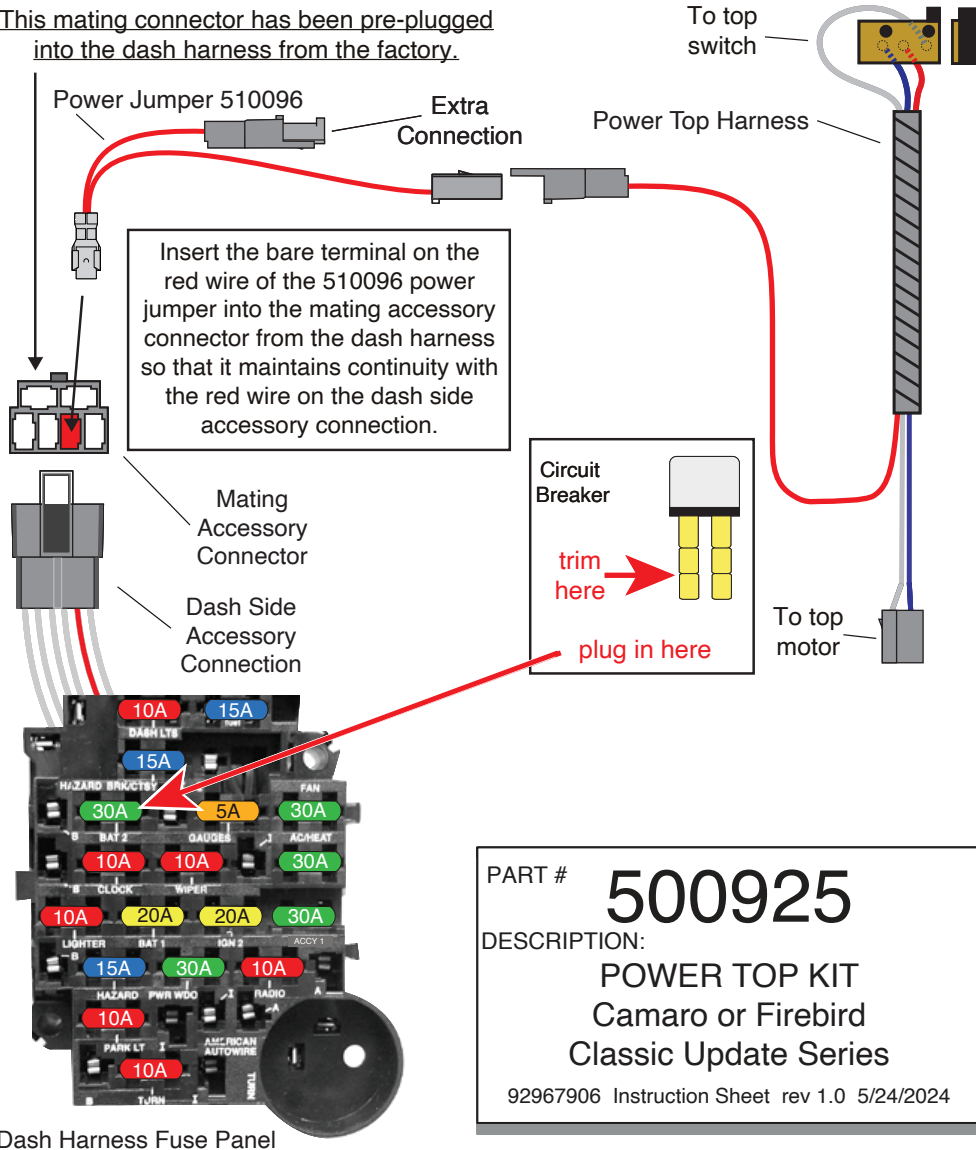

PART # **500925**  
 DESCRIPTION:  
**POWER TOP KIT**  
 Camaro or Firebird  
 Classic Update Series  
 92967906 Instruction Sheet rev 1.0 5/24/2024

Dash Harness Fuse Panel

**INSTRUCTIONS:**

1. Insert the bare terminal end of the 510096 into the mating accessory connector as shown below, then plug that connector back into the dash harness accessory connection.
2. Plug the power top harness, CA71716, into the motor connection and onto the power top switch.
3. Plug the remaining red wire on the CA71716 into the mating connector on the red power jumper harness.
4. Remove the 30A fuse from the "BAT 2" location in the fuse panel and replace it with the provided 30 A circuit breaker. This breaker will need to be trimmed as show below, before inserting.



www.americanautowire.com 856-933-0801

This mating connector has been pre-plugged into the dash harness from the factory.

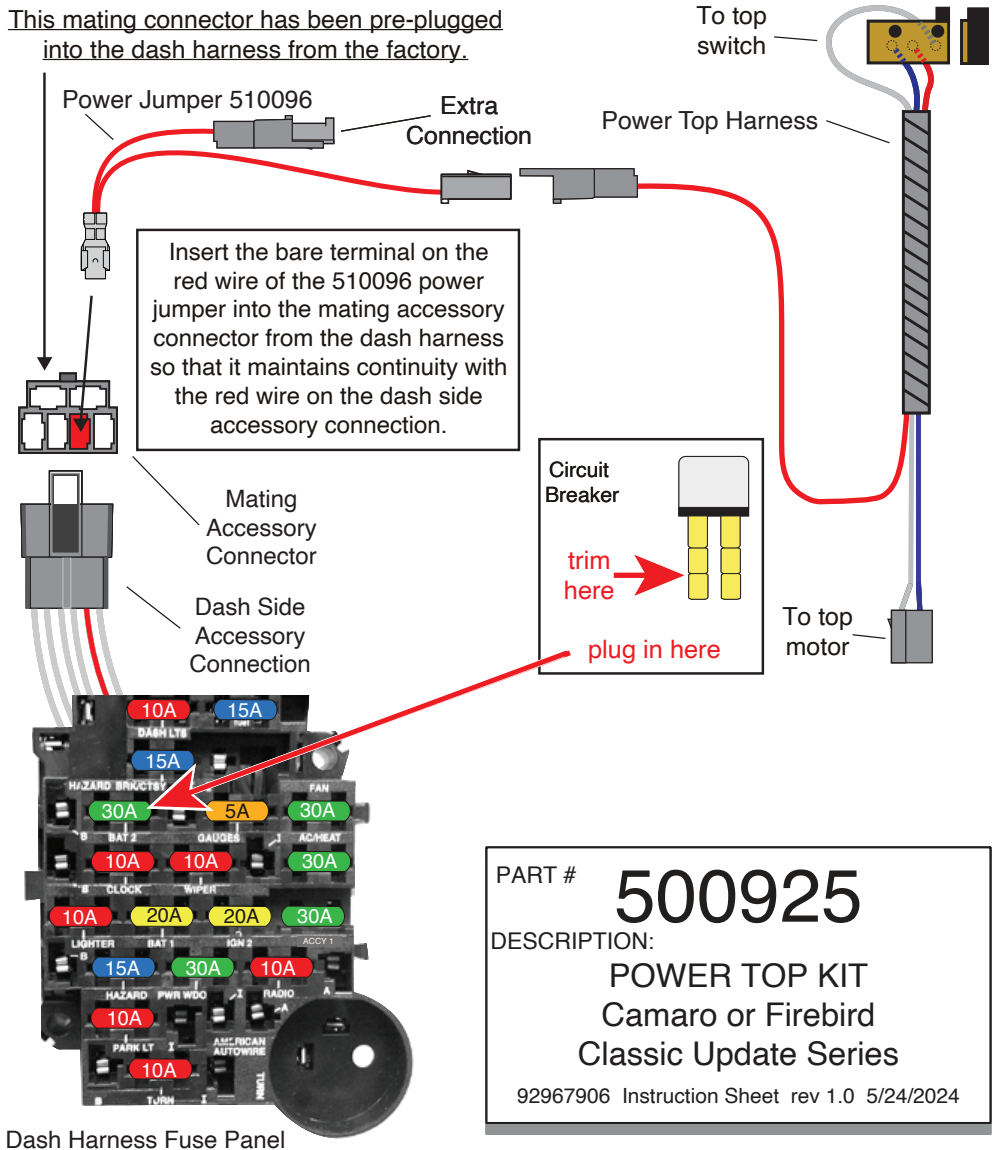

PART # **500925**  
 DESCRIPTION:  
**POWER TOP KIT**  
 Camaro or Firebird  
 Classic Update Series  
 92967906 Instruction Sheet rev 1.0 5/24/2024

Dash Harness Fuse Panel